

# Product Data Sheet

## 产品规格承认书

Product Name/产品名称: COB 铝基 1919 34W/COB Aluminum 1919 34W

Partt Number/文件编号: PDS-COB 铝基 1919 34W/PDS-COB Aluminum 1919 34W

Version Number/版本号: B3

Page Number/页数: Total of 14 pages/ 共 14 页

SDCM /色容差: Standard 标准: (  ) IEC60081 其他/Others

Tolerance/机 差: 1.Test Machine Tolerance Yes  No  / 有无机差

2. On basis of RUNLITE Test Data/按源磊测试数据

Product Application/产品应用: LED indoor lighting/LED 室内照明

Runlite 源磊		Customer 客户 Customer code/客户代码: _____	
Prepared 制作	陈飞	Engineering 工程	
Checked 审核		Quality 品质	
Approved 批准		Approved 批准	

**Please sign and return to our company. Thank you!请签核完成后回传到我司，谢谢!**

## High Power COB /大功率 COB

### CP1919 34W series /CP1919 34W 系列



#### Features /特性

- High Power & High Ra COB / 大功率 & 高显色 COB
- Multi-Chips Solution / 多芯片解决方案
- High luminous intensity output / 高亮度
- RoHS compliant / 符合 RoHS
- Compliance with Energy Star / IEC60081 Binning / 符合能源之星 / IEC60081 标准

#### Description /描述

Runlite's Aluminum based COB can achieve high efficiency and high Ra that compliance with Energy Star / IEC60081 standard.

源磊 COB 产品采用铝基板导热，具有高光通量，高光效，高显指的特性，符合能源之星 / IEC60081 标准

#### Applications /应用

- Down light / 筒灯
- Spot light / 射灯

## Part Number Explanation /产品编码解说

C P 1919 L 34-36 02 W 29S P2P3 F R3R8-0000

C=Product Category/产品类别

P=Product Configuration/产品结构

1919=Product Dimension/产品尺寸

L=Base Material/基板材质

34=Product Power/产品功率

36=Chips in Serial/芯片串联数目

02=Chips in Parallel/芯片并联数目

W=Light Colors/发光颜色

29S=CCT or Wavelength/色温或者波段

P2P3=Brightness/亮度范围

F=Ra/显色指数

R3R8=Voltage Range/电压范围

0000=Serial NO/产品流水码

## Table of Ra /显色指数表格

Symbol / 符号	Description/ 描述
A	No Requested/没有要求
B	60-65
C	65-70
D	70-75
E	75-80
F	80-85
G	85-90
H	90-95
I	95-100

Note/备注:

Tolerance of Ra:  $\pm 2$  显色指数  $\pm 2$

## Mass Production List / 量产清单

Part Number / 产品型号	Ra	CCT(K)	Φ(lm)	Φ(lm)
	Min.(1)		Min. (2)	Max. (2)
CP1919L34-3602W27SQ5Q6FV5V9-CS01	80	2700K	3000	4000
CP1919L34-3602W30YQ5Q6FV5V9-CS01	80	3000K	3000	4000
CP1919L34-3602W34SQ5Q6FV5V9-CS01	80	3400K	3200	4200
CP1919L34-3602W41SQ5Q6FV5V9-CS01	80	4000K	3200	4200
CP1919L34-3602W50SQ5Q6FV5V9-CS01	80	5000K	3200	4200
CP1919L34-3602W57YQ5Q6FV5V9-CS01	80	5650K	3000	4000
CP1919L34-3602W62GQ5Q6FV5V9-CS01	80	6200K	3000	4000

Notes/备注:

1.Tolerance of Ra Index:  $\pm 2$  显色指数  $\pm 2$

2.Tolerance of Luminous flux:  $\pm 11\%$ . 光通量 $\pm 11\%$

## Product Selection Guide/产品指南

Chip Materials / 芯片材料	Emitted Color/ 发光颜色	Resin Color / 胶体颜色
InGaN	Cool White / 正白	Yellow/黄色
InGaN	Neutral White / 自然白	
InGaN	Warm White / 暖白	

**Absolute Maximum Ratings (T<sub>Soldering</sub>=25°C) / 极限参数 (温度=25°C)**

Parameter / 参数	Symbol/ 符号	Min.	Typ.	Max.	Unit / 单位
Input power range / 输入功率范围	P <sub>i</sub>	12.0	33.9	36.0	W
Operating current range / 工作电流范围	I <sub>F</sub>	100	300	320	mA

Parameter / 参数	Symbol/ 符号	Rating / 等级	Unit / 单位
Operating Temperature / 操作温度	T <sub>opr</sub>	-40~+85	°C
Storage Temperature / 存储温度	T <sub>stg</sub>	-40~+100	°C
Junction Temperature / 结温	T <sub>j</sub>	115	°C
Lead Soldering Temperature / 引线焊接温度	T <sub>sol</sub>	Max. 320°C for 5sec Max.	

Note:

- The temperature of Aluminum PCB do not exceed 105°C. If the input power reach 80% max P<sub>i</sub>, the temperature of Aluminum PCB should be control below 100°C  
 基板负极引线温度不能超过 105°C.如果输入功率达到最大输入功率的 80%以上,基板负极引线温度应控制在 100°C以内.
- When hand soldering, keep the temperature of iron below less 320°C less than 5 seconds  
 当手工焊接时,烙铁的温度必须小于 320°C,时间不能超过 5 秒 .
- D.C. Current :  $T_j = T_s + R(j-s) \times P_i$

**Electro-Optical Characteristics (T<sub>Soldering</sub>=25°C) / 光电参数 (温度=25°C)**

Parameter / 参数	Symbol/ 符号	Min.	Typ.	Max.	Unit/单位	Condition/ 条件
Luminous Flux/光通量	Φ	3000	--	4200	lm	I <sub>F</sub> =300mA
Forward Voltage /正向电压	V <sub>F</sub>	108	--	115	V	
Color Rendering Index/显色指数	R <sub>a</sub>	80	--	--	--	
Efficacy/ 光效	--	--	120	--	lm/W	
Thermal Resistance /热阻	R(j-s)	--	1.02	--	°C/W	

Notes:

- Tolerance of Luminous flux: ±11% 光通量±11%
- Tolerance of Forward Voltage: ±3% 正向电压±3%
- Tolerance of R<sub>a</sub> Index: ±2 显色指数 ±2

## Luminous Flux Bin / 光通量 Bin

### 2700K---- CP1919L34-3602W27S\*\*\*\*FV5V9-CS01

Bin Code	Min.	Max.	Unit	Condition
Q5Q6	3000	4000	lm	I <sub>F</sub> =300mA

### 3000K---- CP1919L34-3602W30Y\*\*\*\*FV5V9-CS01

Bin Code	Min.	Max.	Unit	Condition
Q5Q6	3000	4000	lm	I <sub>F</sub> =300mA

### 3400K---- CP1919L34-3602W34S\*\*\*\*FV5V9-CS01

Bin Code	Min.	Max.	Unit	Condition
Q5Q6	3200	4200	lm	I <sub>F</sub> =300mA

### 4000K----CP1919L34-3602W41S\*\*\*\*FV5V9-CS01

Bin Code	Min.	Max.	Unit	Condition
Q5Q6	3200	4200	lm	I <sub>F</sub> =300mA

### 5000K----CP1919L34-3602W50S\*\*\*\*FV5V9-CS01

Bin Code	Min.	Max.	Unit	Condition
Q5Q6	3200	4200	lm	I <sub>F</sub> =300mA

### 5650K----CP1919L34-3602W57Y\*\*\*\*FV5V9-CS01

Bin Code	Min.	Max.	Unit	Condition
Q5Q6	3000	4000	lm	I <sub>F</sub> =300mA

### 6500K----CP1919L34-3602W62G\*\*\*\*FV5V9-CS01

Bin Code	Min.	Max.	Unit	Condition
Q5Q6	3000	4000	lm	I <sub>F</sub> =300mA

## Forward Voltage Bin / 电压 Bin

Group	Bin Code	Min.	Max.	Unit	Condition
V5V9	V5V9	108	115	V	I <sub>F</sub> =300mA

Notes:

1. Tolerance of Luminous flux:  $\pm 11\%$  光通量 $\pm 11\%$
2. Tolerance of Forward Voltage:  $\pm 3\%$  正向电压 $\pm 3\%$

### XY coordinate Macadam 5 step& 3 step/麦克亚当 5 阶/3 阶

Color	Step	CCT(k)	CCT tolerance(k)		Center color coordinates		a	b	theta
			min	max	Cx	Cy			
2700 (27S)	≤3	2722±66K	2656	2788	0.459	0.412	0.00774	0.00411	57.28
	≤5	2722±110K	2612	2832			0.01290	0.00685	
3000 (30Y)	≤3	3047±83K	2964	3130	0.44	0.403	0.00834	0.00408	53.17
	≤5	3047±138K	2911	3188			0.01390	0.00680	
3500 (34S)	≤3	3448±104K	3342	3554	0.409	0.394	0.00951	0.00417	52.97
	≤5	3448±176K	3272	3624			0.01585	0.00695	
4000 (41S)	≤3	4033±142K	3891	4175	0.38	0.38	0.00939	0.00402	54.00
	≤5	4033±237K	3796	4270			0.01565	0.00670	
5000 (50S)	≤3	4992±175K	4817	5167	0.346	0.359	0.00822	0.00354	59.62
	≤5	4992±293K	4699	5285			0.01370	0.00590	
5700 (57Y)	≤3	5625±225K	5400	5850	0.3287	0.3417	0.00760	0.00296	59.46
	≤5	5625±375K	5250	6000			0.01263	0.00493	
6200 (62G)	/	/	/	/	/	/	/	/	/
	/	/	6020	6530			/	/	

### The C.I.E. 1931 Chromaticity Diagram/ C.I.E 1931 打靶图

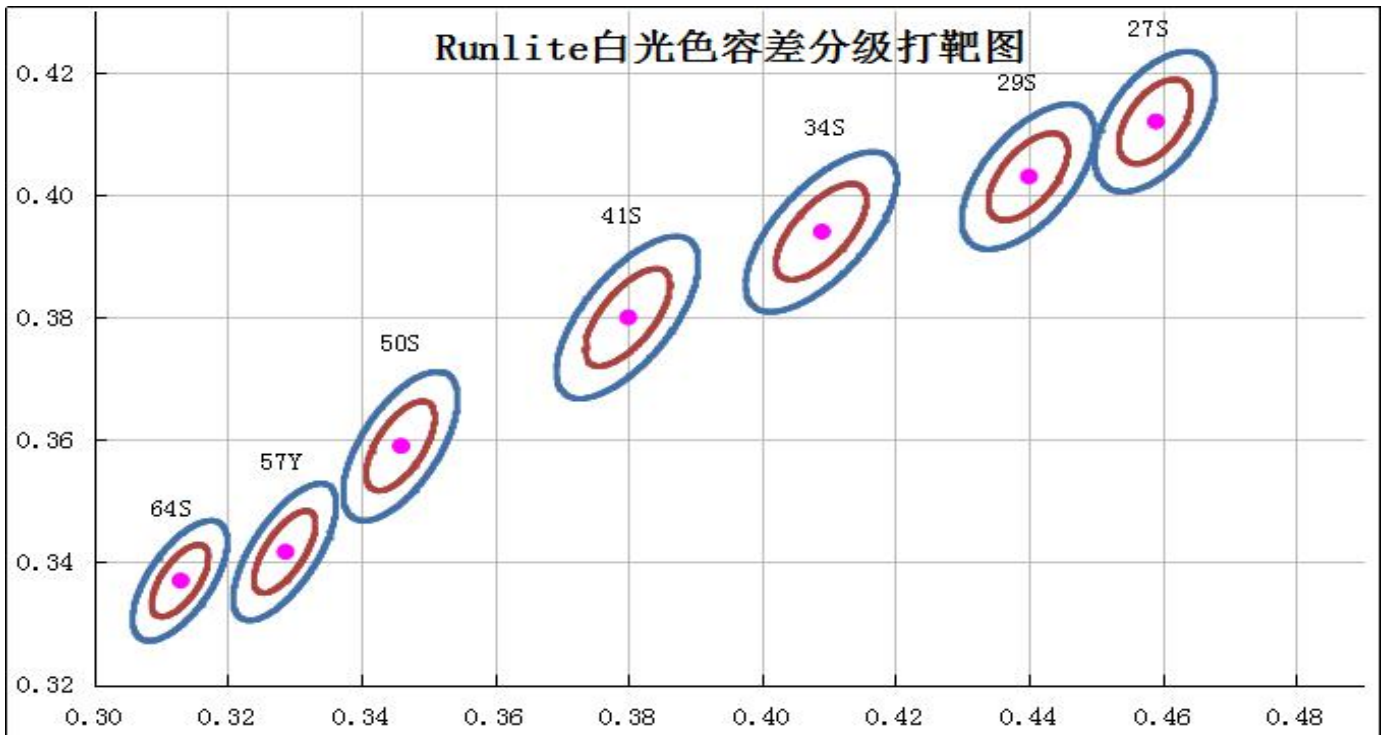

Note:

- 1.The value is based on testing current of 300mA/驱动电流 300mA 瞬态测试参数.
- 2.Tolerance of Chromaticity Coordinates: ±0.01/色度坐标误差 : ±0.01.



## Typical Optical-Electrical Characteristics curves 典型光电特性曲线

**Forward Voltage VS Forward Current**  
电压与电流关系曲线图

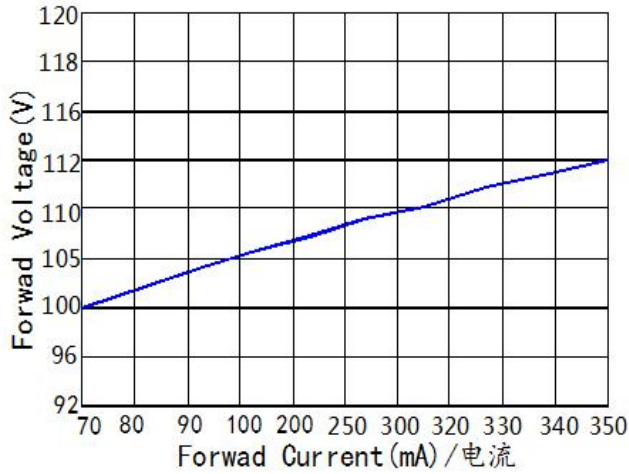

**Relative Luminous VS Forward Current**  
光通量与电流关系曲线图

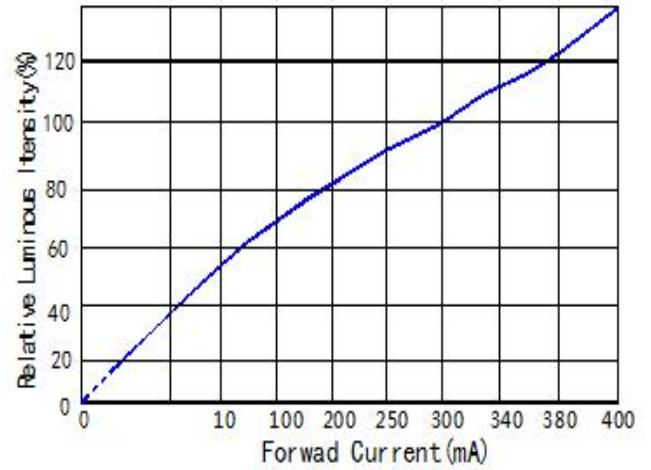

**Case Temperature VS Forward Voltage**  
节点温度与正向电压曲线图  $I_F=300\text{mA}$

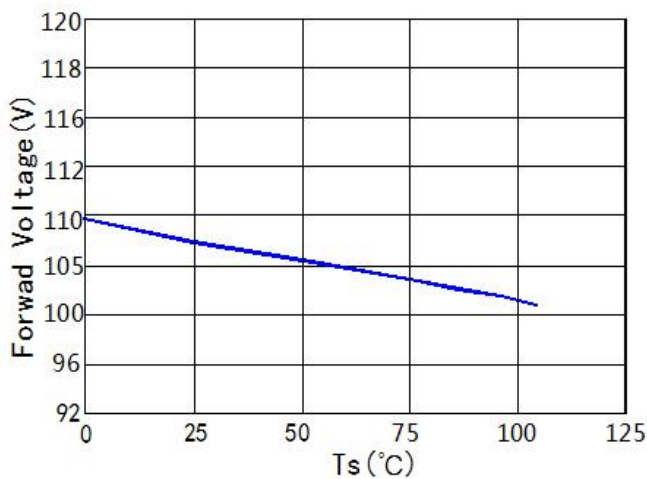

**Case Temperature VS Relative Luminous**  
节点温度与相对流明曲线图  $I_F=300\text{mA}$

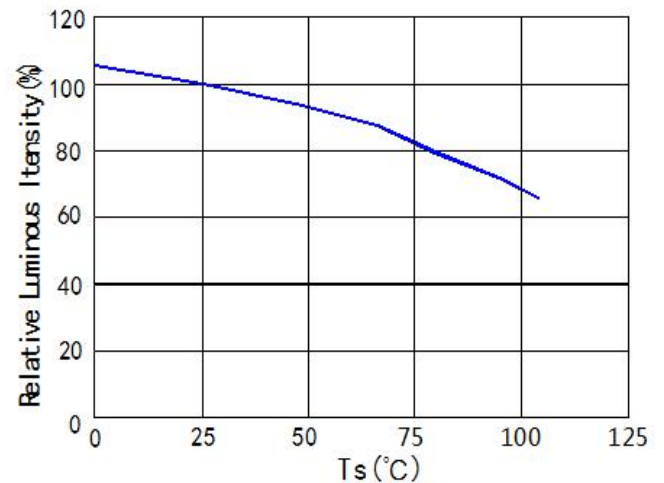

**Typical Spectral Distribution**  
发光角度图 (极坐标)

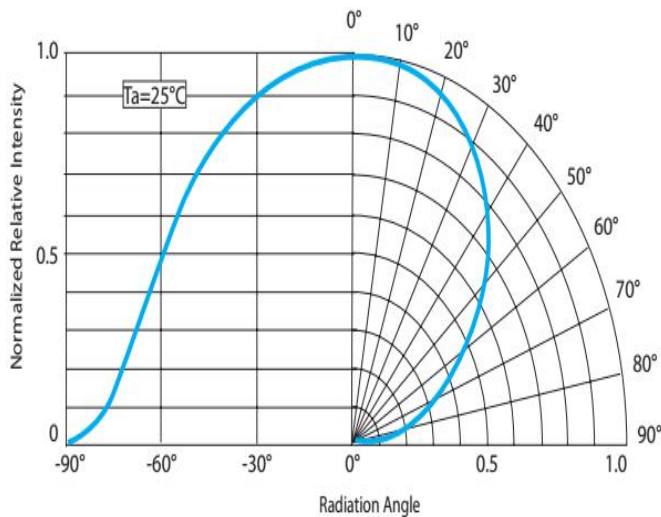

**Wavelength Characteristic**  
相对光谱分布曲线图

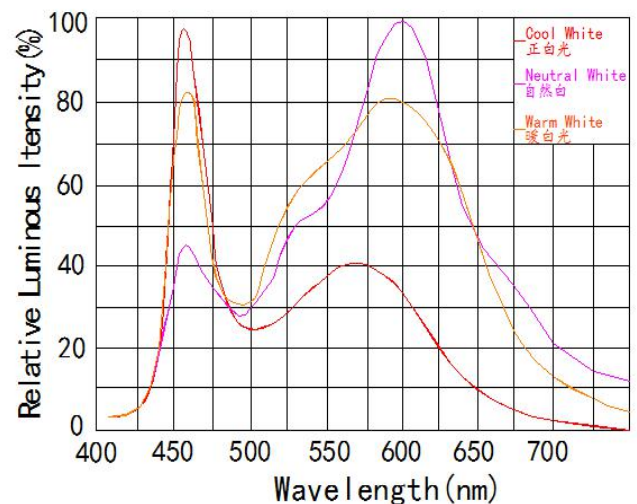



Package Dimension/外形尺寸

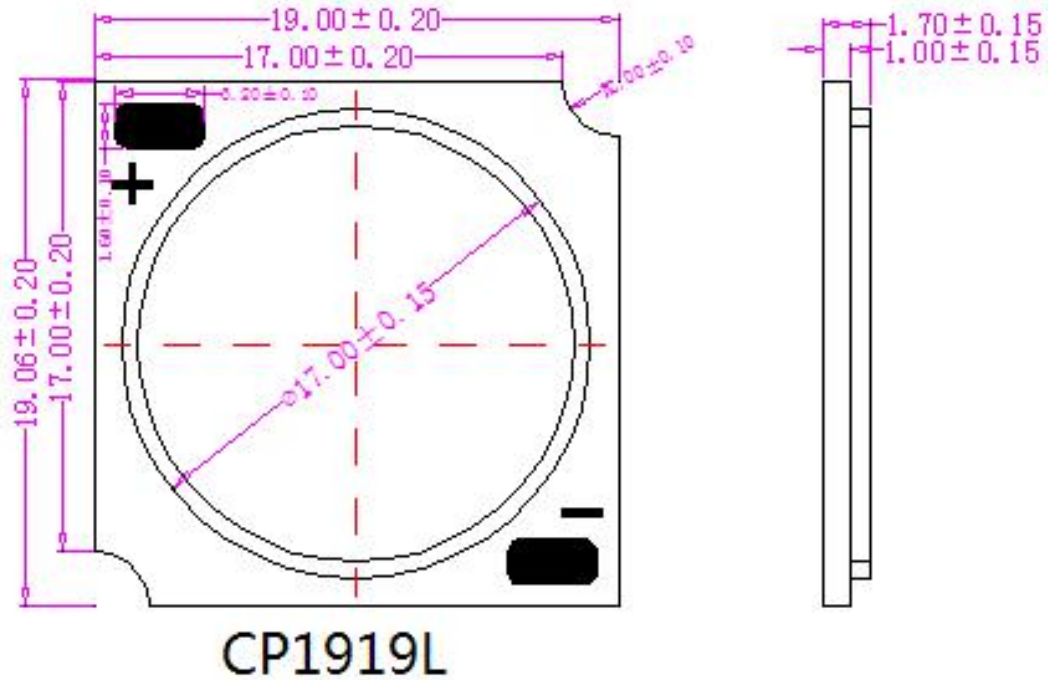

36 串 2 并

Note:

Tolerance unless mentioned is  $\pm 0.20\text{mm}$ ; Unit: mm

若无特别标注，图中尺寸公差为  $\pm 0.20\text{mm}$ ；单位：mm

## Moisture Resistant Packing / 防潮包装

Label / 标签

Tray: Quantity 36pcs Per Reel

托盘规格：36PCS/盒

深圳市源磊科技有限公司 Shenzhen Runlite Technology Co., Ltd				
产品型号	CP1417L06-2402W27H16P1FR1RG-0000	外观描述	8W暖白光	
驱动电流	100MA	批号	180701691-000	
光通量/亮度	850-1000LM	显色指数	Ra ≥ 82	
客户料号	110200000152223	客户订单号	DZ201807240039	
BIN号	色温/波长	电压	数量	8W-27H-27H 201808031779
27H	2645-2805K	66-72V	80 PCS	



### Packing Process/ 包装步骤



准备 PVC 盒



装入料盒



静电袋贴标签



Material in electrostatic bagx4 layers

材料装静电袋 x4 层

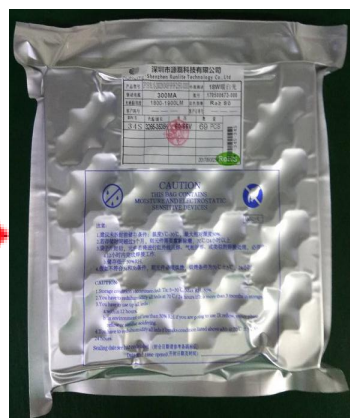

Vacuum sealing

抽真空封口



Pack in cartonx10 packages

纸箱包装 x10 包

## Reliability Test Items / 信赖性测试项目条件

The reliability of products shall be and Conditions below items.

Confidence level : 90%

LTPD : 10%

Test Item 测试项目	Test Conditions 测试条件	Duration/Cycle 持续周期	Quantity 数量	Ac/Re 接收/拒收
Thermal Shock 冷热冲击	-40°C 30min  ↑↓ 5sec  100°C 30min	500 times  循环 500 次	22PCS	0/1
High Temperature Storage 高温储存	Ta=100°C	1000 hours 1000 小时	22PCS	0/1
High Humidity & High Temperature 高温高湿	Ta=85°C  RH=85%	1000 hours 1000 小时	22PCS	0/1
Low Temperature Storage 低温储存	Ta=-40°C	1000 hours 1000 小时	22PCS	0/1
High Temperature Operatiur test 高温老化	Ts=105°C  IF=300mA	1000 hours 1000 小时	22PCS	0/1



## COB LED instruction manual/COB 型 LED 使用说明书

Thanks for using our COB product! Avoiding unnecessary damage to the product that due to mishandle, we are providing you the following guide lines. Please keep in mind that the application has good performance, not only the LED package, but also related to working condition, operation method and whole system design. The recommendation can't covers all application details, hope you can care of this.

感谢您使用我们的 COB 产品，为增进您对我公司产品特性的了解，也为方便您快速掌握产品的基本操作。为尽量减少或避免因人为等因素造成不必要的产品损坏，使其能够更好的为您的生产服务，特针对使用过程中的一些规范使用作相应说明，同时即使是同一规格 LED，在实际应用领域其可靠性与整体系统设计水平、作业方式、使用条件均相关。本使用说明不可能涵盖客户使用过程中可能碰到的所有问题，由此带来的不便，敬请谅解！

### 1. Features:

COB LED is consisted of substrate and silicone in appearance. Positive and negative electrodes on the substrate surface. LED chips are mounted on the substrate and connected by wires, which are covered / protected by silicone with phosphors. Compared with SMD LED, COB LED can directly mount on the heat-sink with soldering and reflow process, that providing a good thermal performance, the luminaire can achieve compact design.

#### 1. 产品特征：

COB 型 LED 封装的构造有基板和硅胶组成，基板由正电极和负电极构成，同时，硅胶部分的基板上贴有 LED 元器件，并使用带有荧光胶的硅胶进行封装。与 SMD 型 LED 封装不同，COB 型 LED 封装可直接安装与散热器上。此外，通过直接将 LED 元器件贴于基板上保证其优异的散热性。使用 COB 型 LED 封装可实现灯具的小型化设计。

#### 2. Attention before usage

2.1. Once the packing of the COB LED is recommend in room temperature (20-30C) with dry ( $\leq 50\%$ ) cabinet or box, which in order to prevent water absorption. It needs to dry bake if the product exposed to air more than 24hours or storage exceed 3 months in packing, the baking condition is 120C/2 hrs.

2.2. Products are keep in plastic tray with ESD bag when transportation, handle with care is need to preventing the damage and failure.

2.3. Handling issue improper will affecting the product performance. No touch of silicone surface, such as finger, nipper, soldering iron, etc; high external stress will cause failure. It is recommend to wear gloves for assembly and not contaminate the product.

#### 2. 使用前注意事项：

2.1、开包装前避免湿气进入 LED 内部，建议 COB 系列 LED 存放在内置干燥剂的干燥柜中，储存环境为温度 20-30°C，湿度不超过 50%。若存储时间超过 3 个月，LED 需要重新除湿（120°C/1-2 小时）。若开包装的 LED 当天未使用完请及时存放干燥柜中，超过 24 小时的请重新除湿（120°C/1-2 小时）再使用。

2.2、COB 型 LED 封装产品在交付时使用托盘包装，在搬运的过程中请勿施加外力挤压，外力挤压会导致产品不亮灯，因此请注意切勿用手指等接触托盘内部。

2.3、不当的产品拿取方式可能会对产品的光学特性及使用寿命造成影响。特别注意不要对硅胶部分施加外力，否则可能会导致产品不亮灯，拿取材料请佩戴防静电手套，切勿徒手接触产品，徒手接触发光部分可能会弄脏表面，从而影响其光学特性。切勿使用镊子等头部较为锐利的工具夹取，与硅胶部分接触可能导致金线断线，从而引发不发光或发光闪烁故障。

### 3. Operation attention

3.1. Silicone is soft and use for the protection of chips and wire, please avoid pressing and touching surface, which causing early failure and performance degrade.

3.2 Handle with care when product assembly and to prevent stack up the products.



3.3. The product is not suitable for the reflow process. Using constant temperature soldering for wires connection, tip of iron should be below 350C and not more than 5 seconds. Soldering point is not recommend to continue welding, it should be cooling down first before re-soldering. Soldering wire and flux should not be touch or contaminate the silicone surface.

### 3、操作注意事项：

3.1、硅胶部分由发光部位和围胶构成，通过围胶成型，请避免对硅胶部位按压或与尖锐的金属接触，否则可能会影响产品的功能及可靠性。

3.2、装入灯具时请勿将硅胶部位与其他组件接触，为防止硅胶部位出现剥落，断线或缺损等情况，请勿将本产品重叠放置。

3.3、本产品部不适合进行回流焊，因此在进行焊接时推荐使用恒温电烙铁，功率在 30W 以内，烙铁头温度在 350 度以下，加热时间在 5 秒以内，不要重复对光源焊接，因当焊接完成一个焊盘待冷却以后再焊接另一个焊盘。注意焊接的引线不要碰触到硅胶部位和铝基板边缘。

### 4. Installation

4.1. It suggests to use M3 screws to mount the product on heat sink. Not touch the silicone when screwing. In order to have good heat dissipation, thermal grease is needs to apply between bottom of COB LED and heat sink surface. It needs to prevent thermal grease the silicone surface.

4.2. COB LED light performance is direct related to input power and operation temperature, heat sink must used for lower the product temperature, the Junction Tj control very important and should not exceed the maximum rating.

### 4、安装方法：

4.1、对 COB 型 LED 封装组装时建议使用 M3 螺丝固定在散热器上，在扭螺丝的过程中切勿对硅胶施加外力。为提高产品的散热性能，请在 LED 封装与散热器之间使用优质导热膏，请将其均匀涂抹在 LED 封装的背面。

4.2、LED 元器件会根据输入的功率而发光和热，但是 LED 封装的表面积非常小，仅靠封装本身向大气进行散热几乎无法实现，因此需要散热片等外接散热器。LED 封装中元件接合点温度 Tj 管控十分重要，在任何条件下均不可以高于规格书中规定的绝对最大额定值。

### 5. Powering method

5.1. COB LED should driving by a constant current source, constant voltage driver is not recommend to use, which will easily damage the product.

5.2. Please to avoid surge current when power on and off, when should not higher than the product maximum current rating.

### 5、驱动方式：

5.1、LED 为恒流驱动器件，客户在选定电源需要根据光源的电流额定电流选择电源的输出电流和电压，防止电流过大烧坏光源或影响性能。

5.2、LED 封装与电容器等容性负载连接时，在开关转换瞬间可能会产生浪涌电流，在使用时应尽可能避免产生浪涌电流，但当无法避免时请采取措施，确保其低于产品的绝对最大额定值。

### 6.Cleaning

Please suing isopropyl alcohol for cleaning only if necessary. Please make sure or test first if use other cleaning agent that not affect the silicone/product performance.

### 6、清洁清洗：

建议使用异丙醇来清洁 LED，如果要采用其他溶剂清洁，一定要确保此溶剂不会对硅胶、支架镀银层等产生影响。若不可避免，清洗前请事先进行试验，以确认是否对 LED 造成不良影响或潜在性隐患。



7. Other attentions

- 7.1 . White LED is made by blue chip and phosphors, the emitting color will change along with driving current. Please take consideration for the design.
  - 7.2. The product do not design for anti-radiation.
  - 7.3. When COB LED directly expose to sunlight or UV for the period of time, the product surface will yellowing and performance degrade.
  - 7.4. Maintain good performance of COB LED, no cleaning, touch, contaminate and covering the silicone materials.
  - 7.5. It is recommend to cover or coating other gel or resin on top of silicone surface.
  - 7.6 . The electrodes on substrate are plated with silver, which is easily react with some element, such as sulfur, halogen(fluorine, chlorine, bromine, Iodine) and oxygen. Soldering and performance degrade will be happen after the chemical reaction.
  - 7.7. The product is compliance with RoHS. Which is design for general lighting. Please contact us with different applications.
7. 其他注意事项：
- 7.1、白光 LED 是由蓝光芯片和特种荧光粉组合。因此 LED 的发光颜色会随着工作电流的变化而变化，使用前应考虑此因素是否能达到预期效果。
  - 7.2、产品的应用不适用于抗辐射的设计。
  - 7.3、LED 长时间暴露在阳光或偶尔暴露在紫外线下可能导致胶体或透镜黄变。
  - 7.4、为保证 LED 光电性能，请保持 LED 发光区域表面清洁，避免手指印或其它异物覆盖。
  - 7.5、不建议在 LED 的硅胶表面覆盖其他与之不兼容的脂类物质。
  - 7.6、LED 支架表面处理采用镀银工艺，单质银易与硫、卤素（氟、氯、溴、碘）等元素发生反应，导致 LED 外观及光色发生变化。故请客户在组装及应用过程需排除上述元素（含灯具、电源原材料，车间生产环境等），避免上述元素与 LED 镀银层发生反应致 LED 失效（光衰、色温漂移、死灯等）。
  - 7.7、产品符合 RoHs 指令，产品主要应用在一般照明。其他领域应用请事先联系我们。

Runlite / 源磊		Customer / 客户	
Prepared / 制作	陈飞	Engineering / 工程	
Checked / 审核		Quality / 品质	
Approved / 批准		Approved / 批准	